

# Mx-RPW

## Room Control Module (Built-In Occupancy Sensor)

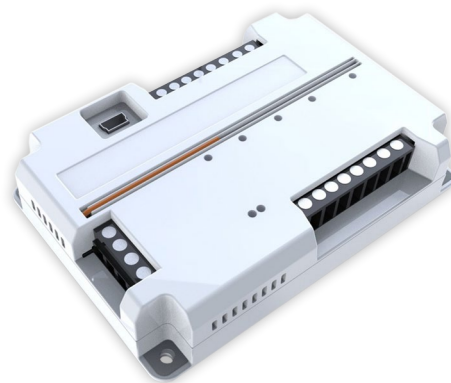

**Mx-RPW**  
*Wireless Room Controller*



**Mx-MTB1**  
*HVAC Control Board (at unit) (sold separately)*

### Application

Solar-powered, self-learning room sensor with LCD and smart communication management for measuring room temperature, independent generation of utilization time profiles and their continuous dynamic adjustment/optimization and for wireless transmission of measured values. Occupancy button for manually changing the comfort mode or economy mode status. In combination with the Mx-MTB transceiver, the Mx-RPW room sensor constitutes a functional unit for easy room temperature control. The Mx-RPW can also be used within additional building automation systems via appropriate gateways (Mx-EBOX, Mx-CBOX)

The following EnOcean Equipment Profiles (EEP) are supported: EEP D2-29-08 \*

\* You can find information about the protocol description on the EnOcean Technology website [http://www.enocean-alliance.org/en/enocean\\_standard/](http://www.enocean-alliance.org/en/enocean_standard/)

### Safety Instructions

This data sheet contains information on installing and commissioning the product "Mx-RPW". Read this product description prior to installation, commissioning or operation. If you have any questions that are not resolved by this data sheet, you can obtain further information from the supplier or manufacturer. If the product is not used in accordance with this data sheet, intended use could be impaired. Unauthorized conversion and modifications to the device are not permitted for safety reasons and will result in the loss of all claims against the manufacturer. The applicable local regulations must be observed when installing and using the device.

# Mx-RPW

## Room Control Module (Built-In Occupancy Sensor)



### Technical Specifications

Part Numbers (Frequency Dependant)	M9-RPW (902 MHz - North America) M8-RPW (868 MHz - Europe and China) MJ-RPW (928 MHz - Japan)
Nominal Voltage	Dual power supply consisting of a solar cell and an internal energy storage unit with priority management Lithium battery (AA) AC 2.3 V; 0,08 W
Measured Quantity	Room temperature in homes or offices
Measuring System	Temperature sensor: - Integrated digital sensor Occupancy sensor: - Integrated PIR ("Passive infrared") sensor
Measuring Range	0 to 40°C or 32 to 104°F
Relative Measurement Precision	0.1 K
Display	LCD: - Room temperature/time, optionally - Status indicators
Controls	- Occupancy button: manually switch between comfort mode/ economy mode, fan speed and auto
Interfaces	EnOcean® wireless interface: - Radio telegram: EnOcean radio telegram, bidirectional - Duty cycle: < 1 % - Cyclic transmission/reception intervals
Communication Cycle	10 min
Transmission Power	< 10 mW
Illumination Strength	Min. 100 lux recommended
Operating Range	Radio: Approx. 30 m in buildings (depending on building structure) Occupancy Sensor: Approx. 10 m
Housing	Plastic housing, RAL 9010 (pure white), 7001 Other colors on request
Protections Class	III
Degree of Protection	IP30
Ambient Temperature	0 to 50°C or 32°F to 122°F
Ambient Humidity	During Operation: 20 to 85% rH, non-condensing; Out of Operation: 5 to 90% rH; non-condensing
Installation	Flexible mounting using screws or adhesive
Maintenance	Maintenance-Free
Weight	0.22 kg
Dimensions	WxHxD: 90 x 153.7 x 26.7 mm

# Mx-RPW

## Room Control Module (Built-In Occupancy Sensor)

### Dimensions

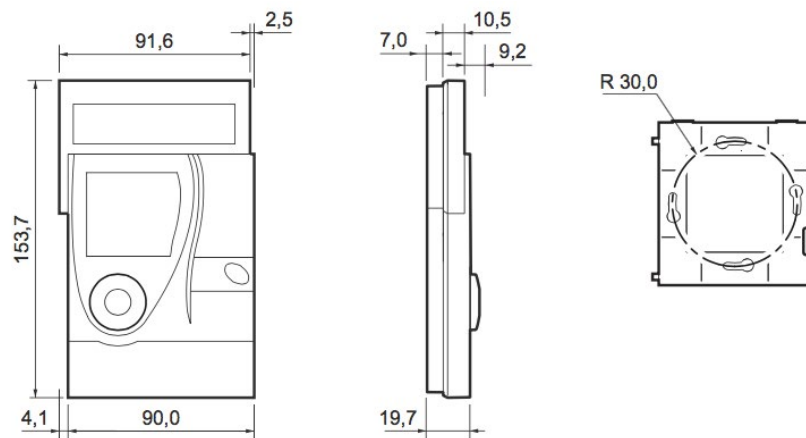

### General Installation Instructions

It is not always possible to freely select the installation location of devices which communicate wirelessly, as radio data transmission is influenced to a greater or lesser extent by structural or spatial factors. In order to establish operational and reliable communication paths, the following aspects must be considered before and during planning:

- Structural factors restrict the transmission ranges which can be reached. Building materials and screening elements (e.g. suspended ceiling elements, installation shafts, fire doors, etc.) must be taken into consideration during planning.

**CAUTION:** Elevated humidity increases natural signal damping

**NOTE:** Recommendation: Plan radio paths horizontally on a single level with max. 30 m between the transmitting and receiving modules.

- Designed only for use in rooms.
- Observe minimum distances to potential sources of interference.
- Min. 0.5 m to high-frequency sources of interference (such as microwaves, transformers or computers)
- Min. 3.0 m to transmitters of other radio systems (such as a cordless telephone or headphones)
- Min. 0.1 m to metal and door frames
- Minimize the effect of wall thickness (for example partition walls or room dividers) by ensuring that the radio signal passes through the walls at as close to a right angle as possible.
- Do not select installation locations in the radio shadow of screening building parts/structures -> No direct reception possible.
- Where the device is installed at the limits of reliability, change the position of the transmitter/ receiver slightly if possible (reduce overlapping effects of radio waves).